

**STEVAL-ISA132V1 24 V 300 W peak power resonant converter**

by Riccardo Tosoni

**Introduction**

This application note describes the features of the STEVAL-ISA132V1 evaluation board at 24 V, 300 W peak power conversion.

The architecture is based on a single-stage LLC resonant converter without PFC using the new L6699 resonant controller.

The L6699 integrates some very innovative functions such as self-adjusting adaptive dead time, anti-capacitive mode protection and a proprietary "safe-start" procedure which prevents hard switching at start-up.

Thanks to the chipset used, the main features of this power supply are:

- very high efficiency under high-load and low-load conditions
- safe start up procedure to avoid hard switching
- hard switching prevention under overload and low-load conditions
- burst mode under low-load conditions with smooth restart to prevent audible noise
- the demo board can deliver more than 300 W peak power for a limited time thanks to the NTC thermal protection positioned near the output diodes.
- continuous power at 30°C ambient temperature is 170 W.
- the MOSFET and diode power devices are in D<sup>2</sup>PAK packages

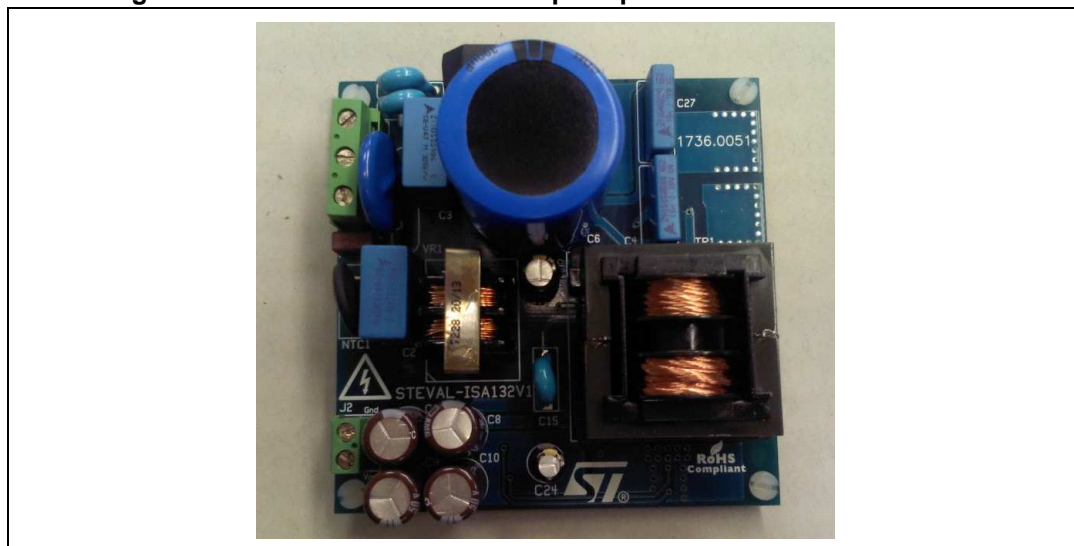
**Figure 1. STEVAL-ISA132V1 300 W peak power SMP evaluation board**

# Contents

- 1 Main features ..... 3**
- 2 Circuit description ..... 4**
  - 2.1 Start-up sequence ..... 4
  - 2.2 Oscillator setting ..... 4
  - 2.3 Burst mode operation at no load or very light load ..... 6
  - 2.4 Brown out ..... 7
  - 2.5 Overload and short circuit protection ..... 7
  - 2.6 Thermal protection ..... 9
- 3 Power components ..... 10**
- 4 Magnetic components ..... 11**
- 5 Functional and thermal test ..... 14**
- 6 Waveform ..... 15**
- 7 Electrical diagram ..... 18**
- 8 Bill of material ..... 19**
- 9 Thermal measures ..... 22**
- 10 EMC precompliance test ..... 23**
- 11 Conclusion and remarks ..... 24**
- 12 Revision history ..... 25**

# 1 Main features

The main features of the SMPS are:

- input mains range: from 190 to 264 V<sub>AC</sub> - frequency 50 Hz
- output voltage: 24 V 5%
- no-load consumption: < 0.6 W
- efficiency @ 230 Vac > 92%
- EMI: Within EN55022 Class-B limits conducted precompliance
- safety: Meets EN60950-1
- dimensions: 90 x 90 mm, 50 mm component maximum height
- weight 220 gr

The circuit consists of a single stage LLC resonant converter.

The MOSFET and diode power components are in D<sup>2</sup>PAK packages.

The L6699 integrates all the functions necessary to control the resonant converter with a 50 % fixed duty cycle and working with variable frequency.

## 2 Circuit description

### 2.1 Start-up sequence

D12, D4, R7, C13 in [Figure 13](#) form the start-up circuit.

When the  $V_{CC}$  voltage reaches L6699  $V_{CCOn}$ , the system begins the start-up sequence and changes the switching frequency from  $f_{start}$  to the operative frequency.

### 2.2 Oscillator setting

Figure 2. Oscillator's internal block diagram

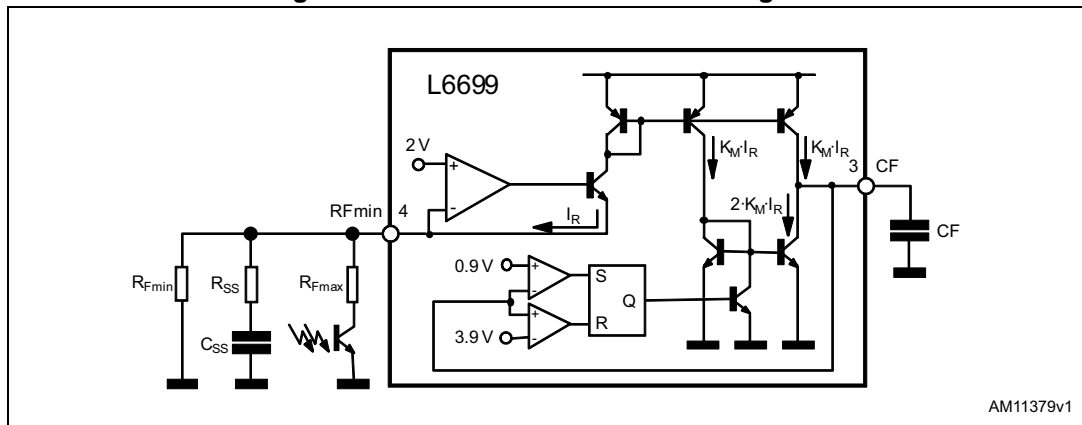

The oscillator is programmed externally by means of a capacitor connected from pin 3 (CF) to ground that is alternately charged and discharged by the current defined with the network connected to pin 4 ( $RF_{min}$ ).

The pin provides an accurate 2 V reference with approximately 2 mA source capability; the higher the current sourced by the pin, the higher the oscillator frequency.

The [Figure 2](#) block diagram shows a simplified internal circuit explaining the operation.

Table 1. Recommended values for CF as a function of the start-up frequency  $f_{start}$

$f_{start}$ [kHz]	CF [pF]	$f_{start}$ [kHz]	CF [pF]
150	680	230 - 240	180
160	560	250	150
170	470	260	120
180	390	270	100
190 - 200	330	280	82
210	270	290	68
210	220	300	56

Procedure to set oscillator components:

- nominate the start frequency (do not exceed 300 kHz  $f_{start}$ )
- find the corresponding value of CF in [Table 1](#)
- with a chosen  $f_{start}$  of 156 kHz, the corresponding CF is 560 pF in [Table 1](#)
- choose the minimum frequency and determine  $RF_{min}$  using the equation:

#### Equation 1

$$F_{min} = \frac{1}{3 * CF * RF_{min}}$$

The chosen  $F_{min}$  is 49.6 kHz, CF is 560 pF and thus  $RF_{min} = 12 \text{ k}\Omega$

Determine  $R_{SS}$  using equation:

#### Equation 2

$$F_{start} = 1 / \left( 3 * CF * \left( \frac{RF_{min} * R_{SS}}{RF_{min} + R_{SS}} \right) \right)$$

For the chosen  $F_{start}$  of 156 kHz, CF = 560 pF,  $RF_{min} = 12 \text{ k}\Omega$  and consequently  $R_{SS} = 5.6 \text{ k}\Omega$

Verify the following relationships:

#### Equation 3

$$R_{SS} = RF_{min} / \left( \frac{F_{start}}{F_{min}} - 1 \right)$$

Choose  $F_{max}$  and determine  $RF_{max}$  using the formula:

#### Equation 4

$$RF_{max} = \frac{3 * RF_{min}}{8 * \frac{F_{max}}{F_{min}} - 1}$$

For a chosen  $F_{max}$  of 150 kHz,  $RF_{max} = 2 \text{ k}\Omega$

Calculate the  $C_{SS}$  using the formula  $C_{SS} = 3 * 0.001 / R_{SS}$

In the application, it may be necessary to increase this value to optimize start-up procedure by minimizing the inrush current and charging current of the output capacitor.

Good performance is achieved with  $C_{SS} = 4.7 \text{ }\mu\text{F}$ .

With reference to the schematic in [Figure 13](#):

- $R_{Fmin} = R18 = 12\text{ k}\Omega$
- $R_{Fmax} = R19 = 3.3\text{ k}\Omega$
- $R_{SS} = R15 = 5.6\text{ k}\Omega$
- $C_F = C22 = 560\text{ pF}$
- $C_{SS} = C26 = 4.7\text{ }\mu\text{F}$

### 2.3 Burst mode operation at no load or very light load

To reduce the average switching frequency, the L6699 can operate in burst mode with a series of a few switching cycles in between relatively long idle periods with both MOSFETs in the off state.

The resulting average value of the residual magnetizing current and corresponding loss is reduced considerably, thus facilitating converter compliance with energy saving specifications.

L6699 can be operated in burst mode via pin 5 (STBY): if the voltage applied to this pin falls below 1.26 V, the IC enters the low-consumption idle state, where both gate drive outputs are low and the oscillator is stopped; the IC resumes normal operation when the voltage on pin exceeds 1.26 V + 30 mV.

To implement burst mode operation, the voltage applied to the STBY pin needs to be associated with the feedback loop.

The resonant converter switching frequency and hence burst mode activation strongly depends on the variation of the input voltage.

Use the circuit in [Figure 3](#) when the input voltage range is quite large.

Due to the high non-linear relationship between the switching frequency and input voltage, it is more practical to empirically determine the correct magnitude for  $R_A/(R_A+R_B)$  correction and  $R_{Fmax}$  to obtain an almost constant burst mode threshold in all input voltage ranges.

In this application, we obtained a good compromise with  $R_A = 56\text{ k}\Omega$ ,  $R_B = 150\text{ k}\Omega$  and  $R_{Fmax} = 3.3\text{ k}\Omega$ .

**Figure 3. Wide input voltage range schematic**

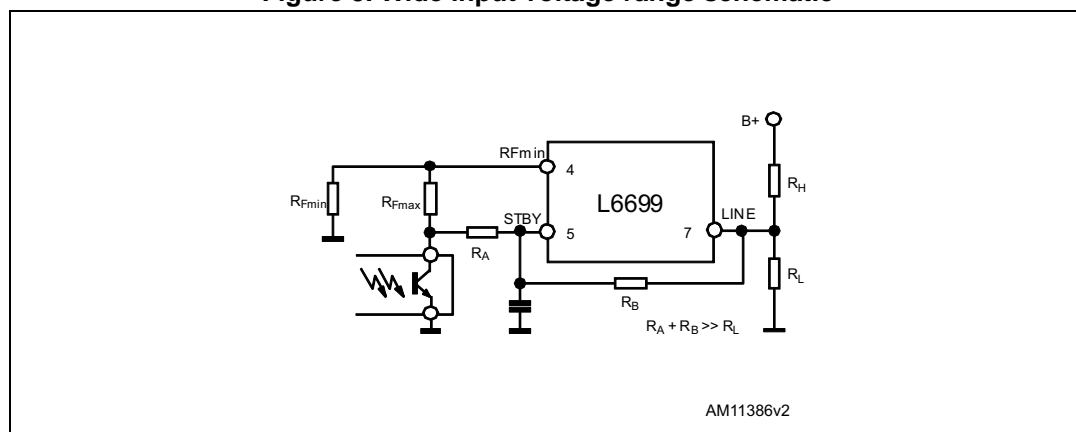

With reference to the schematic in [Figure 13](#):

- $R_A = R_{26} = 56 \text{ k}\Omega$
- $R_B = R_6 = 150 \text{ k}\Omega$
- $R_H = R_1 + R_5 = 3 \text{ M}\Omega$
- $R_L = R_8 = 27 \text{ k}\Omega$

## 2.4 Brown out

Referring to [Figure 13](#), the Line pin is connected to the high voltage input bus with a resistor divider: R1, R5 and R8.

The partition is slightly influenced by resistors R6 and R26.

A voltage below 1.25 V shuts down the IC and consequently lowers consumption and discharges the soft start capacitor.

IC operation is enabled when the voltage exceeds 1.25 V – the comparator is provided with current hysteresis: an internal 13  $\mu\text{A}$  current generator remains on while the voltage applied at the Line pin is below 1.25 V.

Test results:

Decreasing  $V_{IN}$  shut down is 100  $V_{AC}$

## 2.5 Overload and short circuit protection

Referenced to [Figure 4](#).

In the L6699, the current sense input ISEN (pin 6) monitors the current flowing in the resonant tank to perform multiple tasks:

1. primary overcurrent protection
2. hard-switching cycle prevention at start up
3. hard-switching cycle prevention during operation

The ISEN pin is able to withstand negative voltages in order to observe the voltage and current of the resonant tank.

ISEN is internally connected to the input of a first comparator referenced to  $V_{ISENX}$  (0.8 V typ.) and a second comparator referenced to 1.5 V.

If the voltage applied to ISEN exceeds 0.8 V, the first comparator is tripped which in turn activates an internal switch for 5  $\mu\text{s}$ , thus discharging the soft-start capacitor  $C_{SS}$ .

This increases oscillator frequency, limiting the energy transfer.

The circuit shown in [Figure 4](#) operates as a capacitive current divider.

$C_s$  is typically selected with a value around  $C_r/100$  and the sense resistor is selected as:  $R_S = 0.77 / I_{crpkx} * (1 + C_r / C_s)$ .

The OCP limits primary to secondary energy flow in case of overload or short circuit, but the output current in the secondary winding and in the rectifiers can still rise to dangerous levels.

To prevent any damage and reduce power loss, the converter must be forced to operate intermittently.

The DELAY pin manages the timing of the overcurrent protection.

A resistor and a capacitor are connected from this pin and GND to set the maximum duration of an overcurrent condition before the IC stops switching and the delay after which the IC restarts switching.

Every time the voltage on the ISEN pin exceeds 0.8 V, the capacitor on the DELAY pin is charged by 350  $\mu$ A and is slowly discharged by the external resistor.

If the voltage on the DELAY pin reaches 2 V, the soft start capacitor is completely discharged to push the switching frequency to its maximum value and a 350  $\mu$ A current source is kept on.

When the voltage on the DELAY pin exceeds 3.5 V, the IC stops switching and internal 350  $\mu$ A generator is turned off, causing the voltage on the pin to decay because of the external resistor.

The IC enters soft-restart when the voltage drops below 0.3 V.

In this way, the converter under short-circuit or overload condition works intermittently with very low input average power.

If the ISEN pin voltage exceeds 1.5 V, the L6699 is immediately stopped and the 350  $\mu$ A current source is kept ON until the DELAY pin voltage reaches 3.5 V, at which time the generator is turned OFF and the voltage on the pin decays because of the external resistor; also in this case the IC enters soft-restart when the voltage drops below 0.3 V

Is not easy to find a relationship that links charging time to the CDELAY value, so it is more practical to determine CDELAY experimentally.

To give an approximate indication:

- the time to reach 2 V on the DELAY pin is 100 ms every 1  $\mu$ F;
- the time from 2 V to 3.5 V is about  $4.3 \cdot C_{DELAY}$ ;
- the time to discharge CDELAY pin from 3.5 V to 0.3 V is about  $2.4 \cdot R_{DELAY} \cdot C_{DELAY}$ .

Referring to [Figure 13](#), the resistor and capacitor on the DELAY pin are  $C_{21} = 470$  nF and  $R_{29} = 330$  k $\Omega$ .

The protection times are:

- approx. 50 ms: slowly increase frequency
- approx. 1.8  $\mu$ s force frequency to  $f_{start}$
- about 370 ns: switching is stopped

If the overload is less than 50 ms, the system functions as a power limiter without shutdown.



Figure 4. Current sensing lossless capacitive current divider

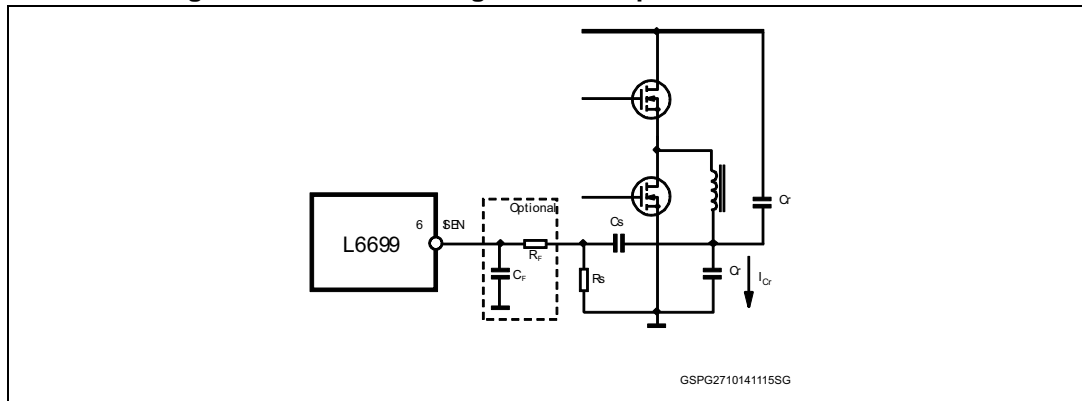

## 2.6 Thermal protection

To render the application unbreakable, it was necessary to apply thermal protection near the output diodes, the warmest area on the power (PWR) supply.

A thermal resistor NTC2 in partition with the R2 resistance is processed by a TSM103W, used as comparator with high hysteresis.

When the output diodes reach 120 °C, the output of TSM103W drives Q3 to drain the current from the optocoupler. The PWR supply shuts off and stays off as long as TSM103W is supplied.

### 3 Power components

Q1 and Q2 are STB13N60M2 series MOSFETs featuring MDmesh™ M2 technology.

They are suitable for resonant types, and are highly rugged to withstand hard switching; they reduce losses from switching turn-off commutation and reduce the current consumption due to  $Q_g$ .

The D3 and D5 STPS20M80CG diodes are optimized to balance leakage current and voltage drop; they are avalanche rated with a high-junction temperature capacity of 175 °C.

# 4 Magnetic components

Figure 5. Transformer (Code 05801 Class Code 1860.0044 Magnetica)

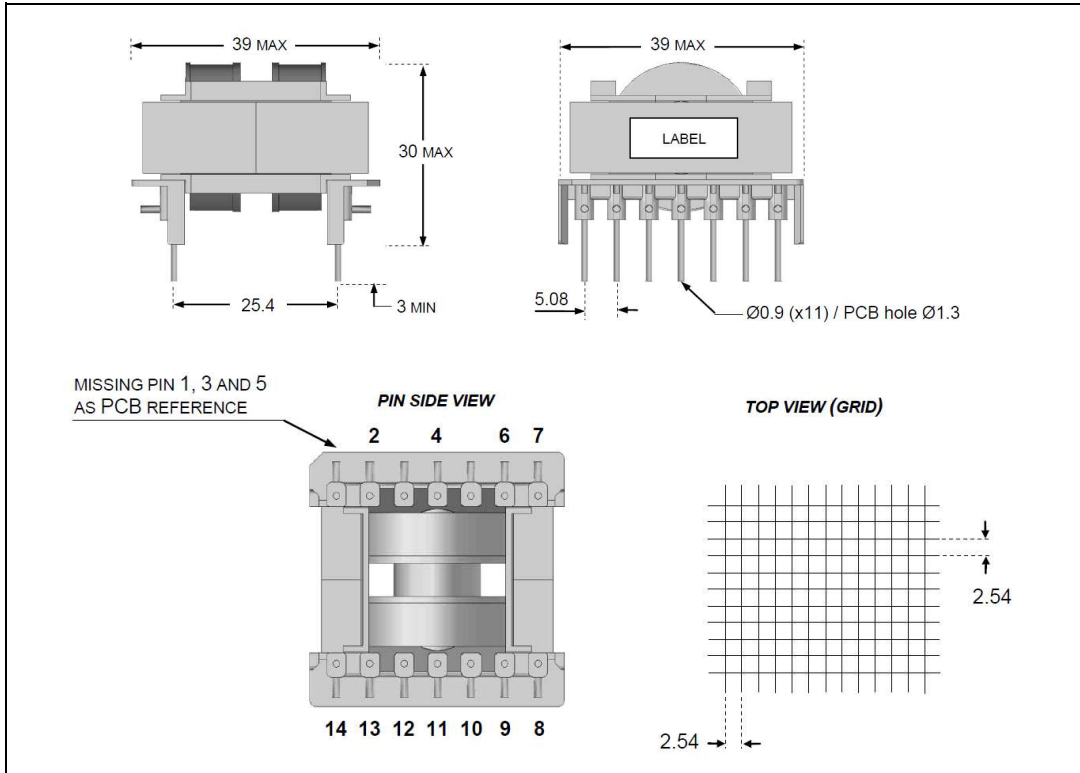

Table 2. Pin functions

Pin n°	Function	Pin n°	Function
1	Not connected	8 <sub>A</sub>	Secondary A
2	Primary Drain/source	9 <sub>A</sub>	
3	Not present	10 <sub>B</sub>	Ground secondary
4	Primary with CR	11 <sub>B</sub>	
5	Not present	12 <sub>B</sub>	
6	Auxiliary (12 V 50 mA)	13 <sub>C</sub>	Secondary B
7	Auxiliary ground (12 V 50 mA)	14 <sub>C</sub>	

200 W<sub>MAX</sub>  
24 V 8.3 A

Figure 6. Transformer electrical diagram and features

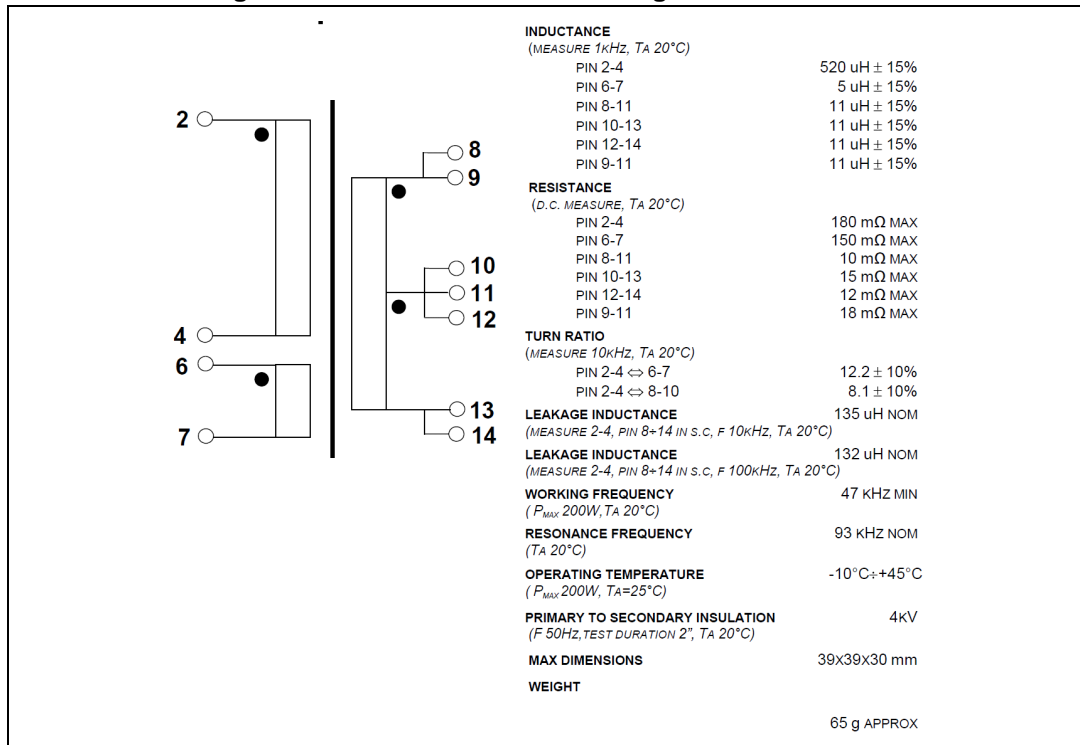
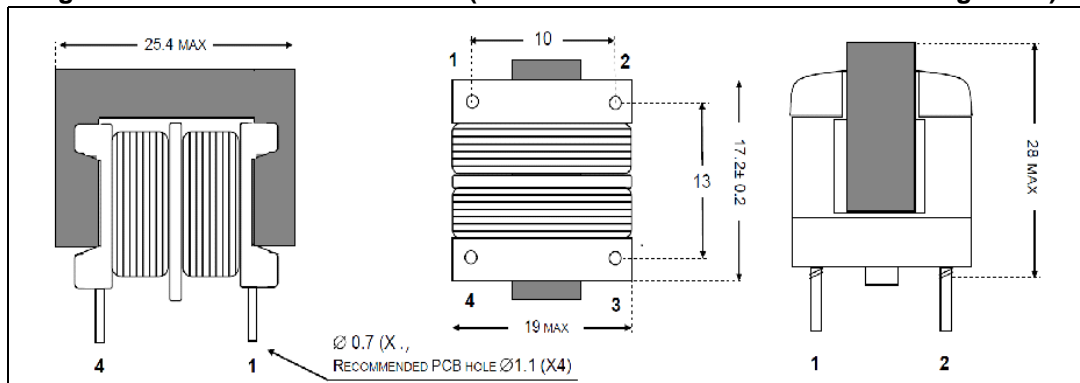

Figure 7. Common mode inductor (Code 07228 Class Code 2258.0001 Magnetica)



- inductance (1-2 = 4-3) 10.5 mH min
- (measured 1 kHz, T<sub>A</sub> 20 °C)
- resistance (1-2 = 4-3) 240 m max
- (measured DC, T<sub>A</sub> 20 °C)
- leakage inductance 0.53% nom
- (measured 1-2 and 4-3 in S.C, F 10 kHz, T<sub>A</sub> 20 °C)
- operating current 1.8 A max
- (measured 1-2 and 4-3, T<sub>A</sub> 20 °C)
- operating frequency 50–60 Hz
- (current 1.8 A Max, T<sub>A</sub> 20 °C)
- insulation (1-2 4-3) 1500 V max
- (F 50 HZ, duration test 2", T<sub>A</sub> 20 °C)
- ambient temperature range: -20 °C to +85 °C

- ( $I_R$  1.8 A max, with self  $t_{rise}$  45 °C)
- thermal CLASS B
- storage temperature range: -20 °C to +85 °C
- maximum dimensions: 25.4 x 19, H 28 mm, weight 18 g approx.

## 5 Functional and thermal test

**Table 3. Functional and thermal test**

	Test	190 Vac	230 Vac	265 Vac
Functional	Tstart (sec)	3.9	3	2.2
Functional	Pin no load (W)	1	0.6	0.5
Functional	$\eta$ @load 6.5 A (%)	91	92	93
Functional	$\eta$ @load 3.5 A (%)	91.5	92.5	93.5
Functional	Freq @ load6.5A (kHz)	66	80	98
Functional	ILimit (A)	12	13.5	16
Thermal	Delay time thermal protection 200 W (sec)		45	
Thermal	Delay time thermal protection 250 W (sec)		32	

All the measurements are typical and performed at 30 °C ambient temperature.

Thermal testing is performed starting with a power of 100 W applied for 30 min.

# 6 Waveform

Figure 8.  $I_{RES}$  &  $V_{HB}$  load 6.5 A  $V_{IN}$  min.

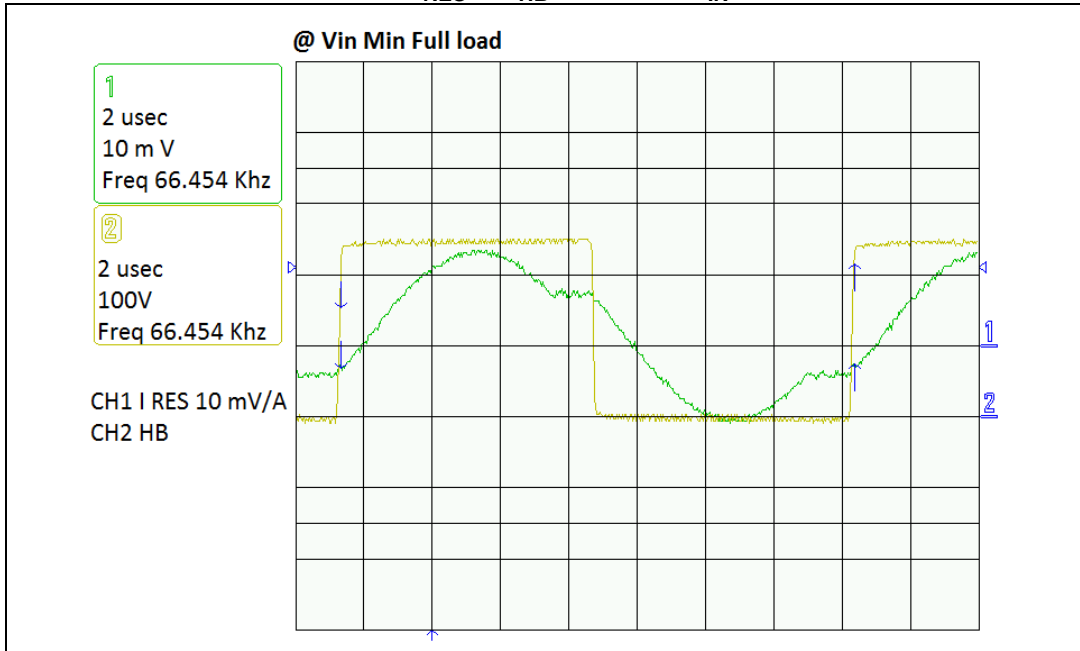

Figure 9.  $I_{RES}$  &  $V_{HB}$  load 6.5 A  $V_{IN}$  nom.

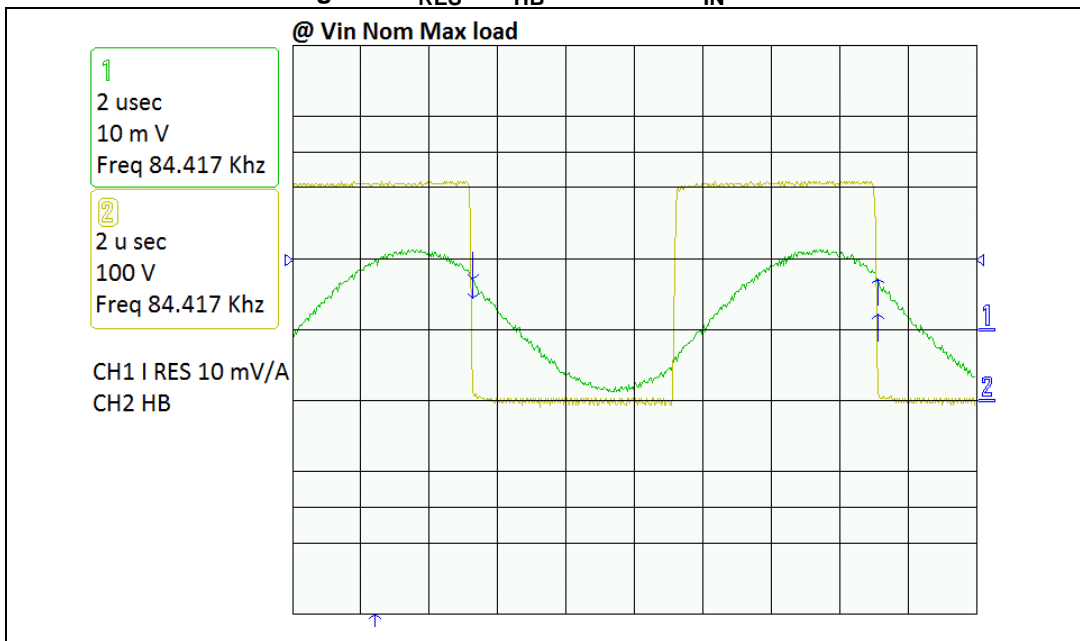

Figure 10.  $I_{RES}$  &  $V_{HB}$  load 6.5 A  $V_{IN}$  max

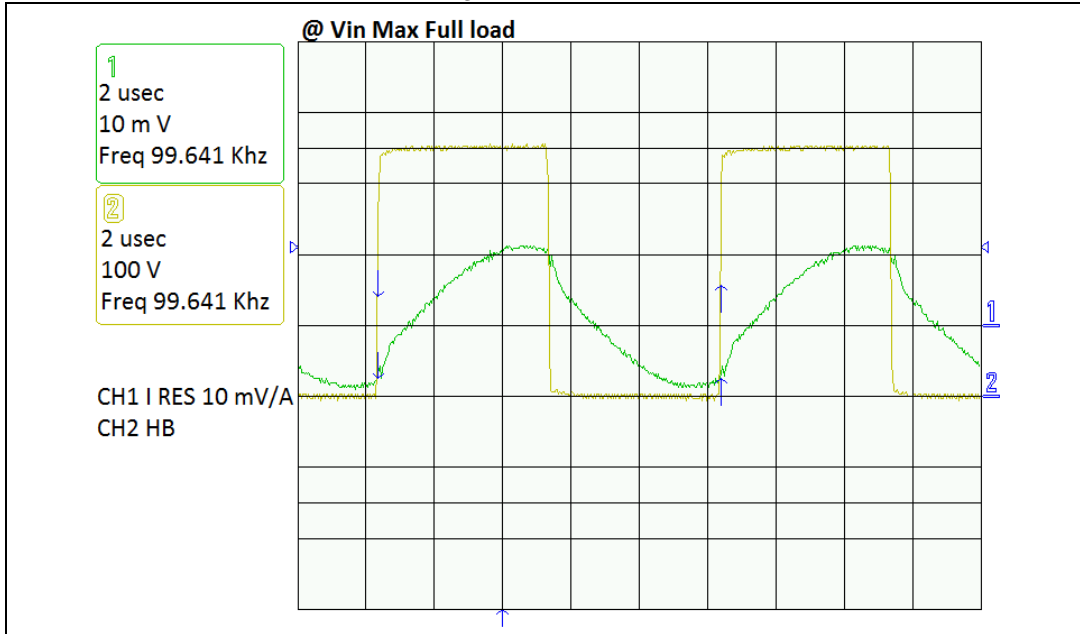

Figure 11. Startup @ 230 V<sub>AC</sub>

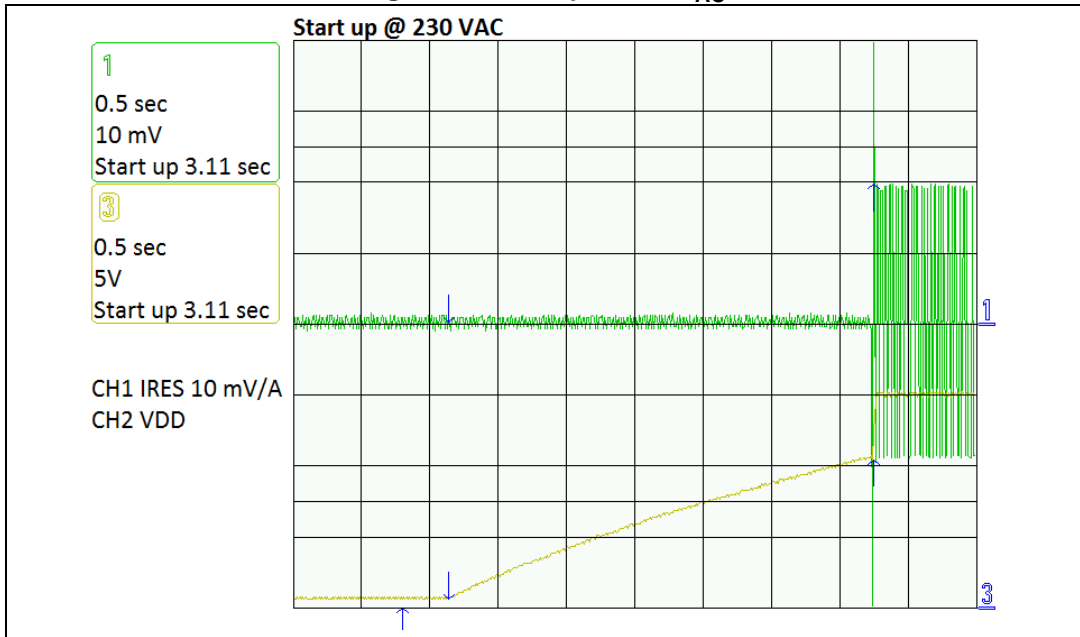
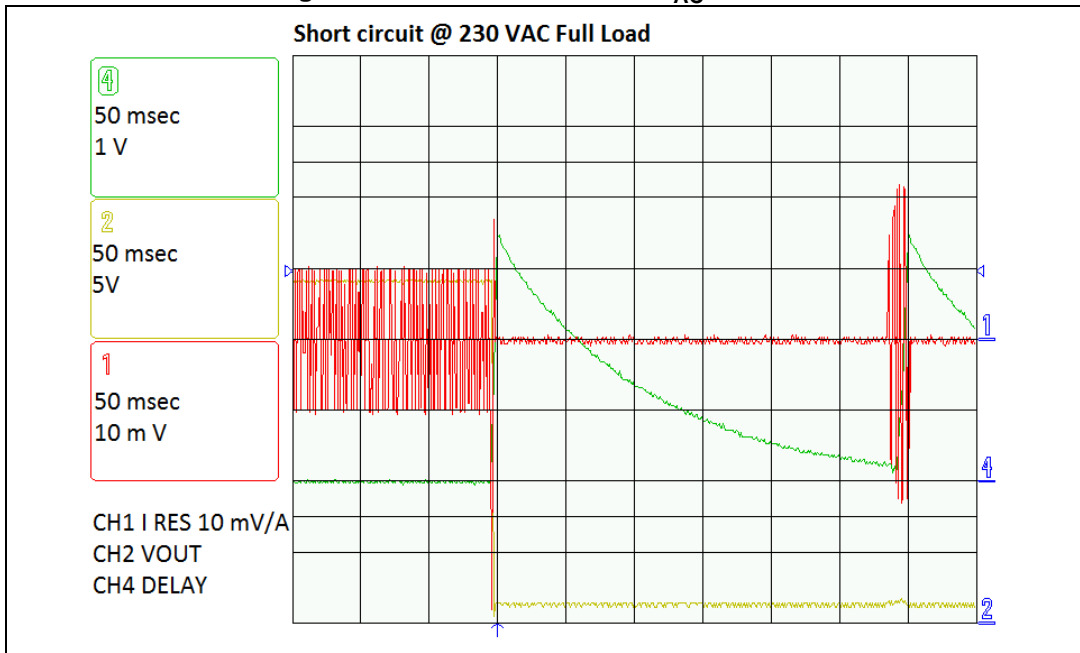

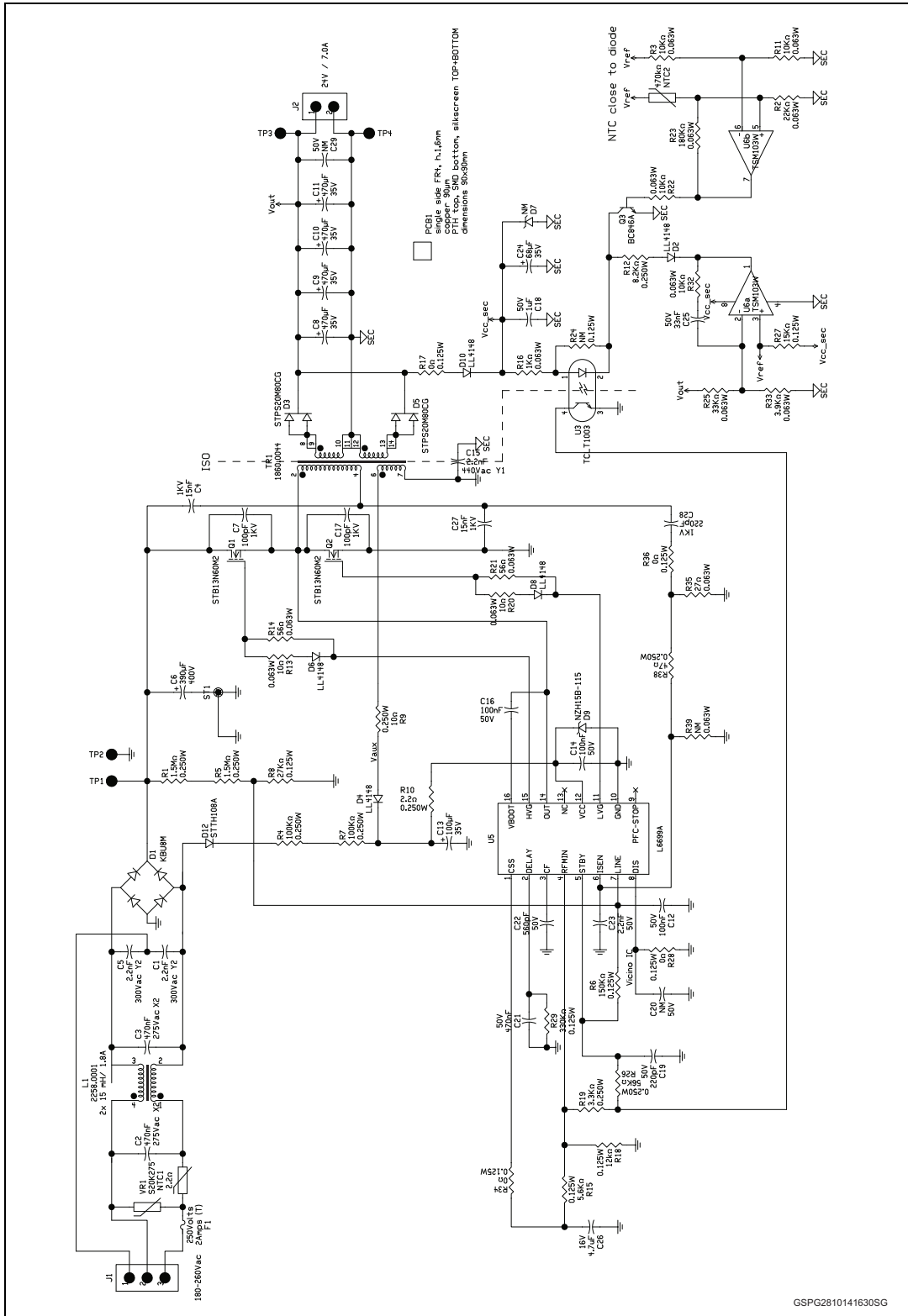

Figure 12. Short circuit @ 230 V<sub>AC</sub> full load



# 7 Electrical diagram

Figure 13. Electrical diagram



GSPG2810141630SG



## 8 Bill of material

Table 4. Bill of material

Type/Value	Modifier	Part number	Manuf.	Description	Qty	Reference IDs
NM	50V	Generic	Generic	Generic capacitor - 0805	1	C20
NM	50V	Generic	Generic	Generic capacitor - 1206	1	C29
100pF	1KV	Generic	Generic	Generic capacitor - 1206	2	C7, C17
220pF	1KV	Generic	Generic	Generic capacitor - 1206	1	C28
220pF	50V	Generic	Generic	Generic capacitor - 0805	1	C19
560pF	50V	Generic	Generic	Generic capacitor - 1206	1	C22
2.2nF	300Vac Y2	PHE850EA4220M A01R	KEMET	Generic capacitor - P10.0	2	C1, C5
2.2nF	300Vac Y1	Generic	KEMET	Generic capacitor - P10.0	2	C15
2.2nF	50V	Generic	Generic	Generic capacitor - 0805	1	C23
15nF	1KV	B32652A1153J	EPCOS	Generic capacitor - P15.0	2	C4, C27
33nF	50V	Generic	Generic	Generic capacitor - 0805	1	C25
100nF	50V	Generic	Generic	Generic capacitor - 0805	2	C12, C14
100nF	50V	Generic	Generic	Generic capacitor - 1206	1	C16
470nF	275Vac X2	Generic	Generic	Generic capacitor - P15.0	2	C2 C3
470nF	50V	Generic	Generic	Generic capacitor - 0805	1	C21
1μF	50V	Generic	Generic	Generic capacitor - 1206	1	C18
4.7μF	16V	Generic	Generic	Generic capacitor - 0805	1	C26
68μF	35V	Generic	Generic	Generic polarized capacitor -P3.5	1	C24
100μF	35V	Generic	Generic	Generic polarized capacitor -P3.5	1	C13
390μF	400V	Generic	Generic	Generic polarized capacitor -P10.0	1	C6

Table 4. Bill of material (continued)

Type/Value	Modifier	Part number	Manuf.	Description	Qty	Reference IDs
470µF	35V	Generic	Generic	Generic polarized capacitor -P5.0	4	C8, C9, C10, C11
KBU8M	-	Generic	Generic	Full-wave Bridge rectifier	1	D1
LL4148	-	Generic	Generic	Generic small signal diode - SOD80	5	D2, D4, D6, D8, D10
NM	-	Generic	Generic	Zener diode - SOD123	1	D7
NZH15B-115	15V	NZH15B-115	NXP	Zener diode - SOD123	1	D9
STPS20M80CG	20A - 80V	STPS20M80CG	ST	Dual common-cathode diode	2	D3, D5
STTH108A	1A - 800V	STTH108A	ST	Generic diode	1	D12
2Amps (T)	250Volts	39212000000	LITTLEFUSE	Fuse - P5.08	1	F1
SIP header	2-pin	796949-3	TE AMP	2-pin Single in-line connector - P5.08	1	J2
SIP header	3-pin	282845-3	TE AMP	3-pin Single in-line connector - P7.62	1	J1
22580001	2x 15 mH/ 1.8A	22580001	MAGNETICA	Common mode choke	1	L1
2.2ohms	-	B57237S0229M0	EPCOS	Inrush NTC	1	NTC1
470kohms	0603	B57371V2474	EPCOS	NTC	1	NTC2
BC846A	SOT23-3	BC846A	NXP	NPN Generic	1	Q3
STB13N60M2	11A - 600V	STB13N60M2	ST	N-Channel MOS FET	2	Q1, Q2
0ohms	0.125W	Generic	Generic	Generic resistor	4	R17, R28, R34, R36
NM	0.125W	Generic	Generic	Generic resistor	1	R24
2.2ohms	0.250W	Generic	Generic	Generic resistor	1	R10
10ohms	0.063W	Generic	Generic	Generic resistor	2	R13, R20
10ohms	0.250W	Generic	Generic	Generic resistor	1	R9
27ohms	0.063W	Generic	Generic	Generic resistor	1	R35
47ohms	0.250W	Generic	Generic	Generic resistor	1	R38
56ohms	0.063W	Generic	Generic	Generic resistor	2	R14, R21
1Kohms	0.063W	Generic	Generic	Generic resistor	1	R16
3.3Kohms	0.250W	Generic	Generic	Generic resistor	1	R19
3.9Kohms	0.063W	Generic	Generic	Generic resistor	1	R33
5.6Kohms	0.125W	Generic	Generic	Generic resistor	1	R15
8.2Kohms	0.250W	Generic	Generic	Generic resistor	1	R12

Table 4. Bill of material (continued)

Type/Value	Modifier	Part number	Manuf.	Description	Qty	Reference IDs
10Kohms	0.063W	Generic	Generic	Generic resistor	4	R3, R11, R22, R32
12kohms	0.125W	Generic	Generic	Generic resistor	1	R18
15Kohms	0.125W	Generic	Generic	Generic resistor	1	R27
22Kohms	0.063W	Generic	Generic	Generic resistor	1	R2
27Kohms	0.125W	Generic	Generic	Generic resistor	1	R8
33Kohms	0.063W	Generic	Generic	Generic resistor	1	R25
56Kohms	0.250W	Generic	Generic	Generic resistor	1	R26
100Kohms	0.250W	Generic	Generic	Generic resistor	2	R4, R7
150Kohms	0.125W	Generic	Generic	Generic resistor	1	R6
180Kohms	0.063W	Generic	Generic	Generic resistor	1	R23
330Kohms	0.125W	Generic	Generic	Generic resistor	1	R29
1.5Mohms	0.250W	Generic	Generic	Generic resistor	2	R1, R5
18600044	520 $\mu$ H/80kHz	18600044	MAGNETI CA	Resonant transformer	1	TR1
L6699D	-	L6699D	ST	Resonant PWM Control	1	U5
TCLT1003	-	TCLT1003	Vishay	Optocoupler	1	U3
TSM103W	-	TSM103W	ST	Generic	1	U6
S20K275	275Vac	B72220P3271K10 1	EPCOS	Varistor	1	VR1

## 9 Thermal measures

Figure 14. Thermal map

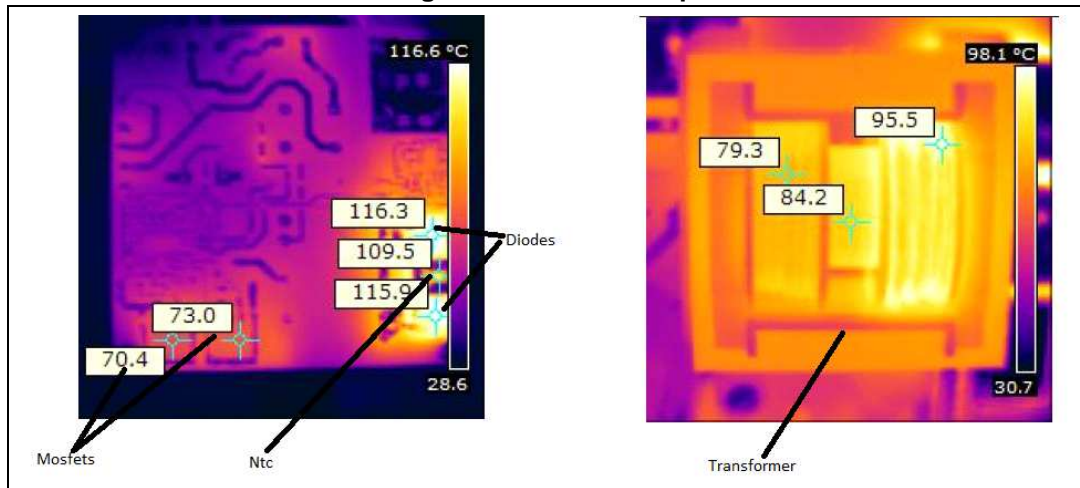

230 V<sub>AC</sub> Load 7 A steady thermal after 2 h T<sub>amb</sub> 30° C

### summary

- Trasfo Copper 95.5 °C
- Trasfo Core 84.2 °C
- secondary diodes 118.8 °C
- primary MOSFETs 73.6 °C
- common mode choke 69.4 °C

# 10 EMC precompliance test

Figure 15. EMC test 150 W

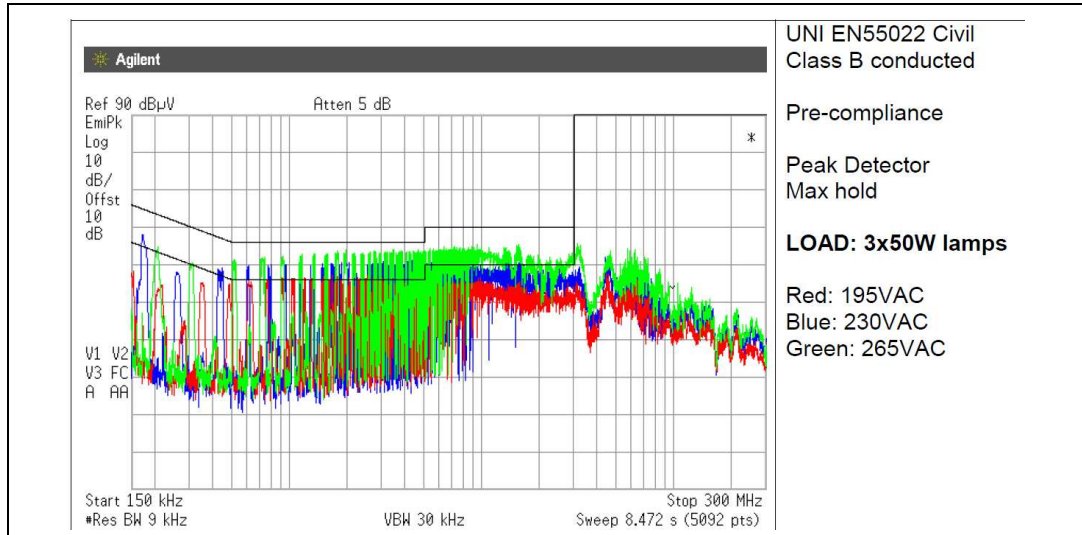
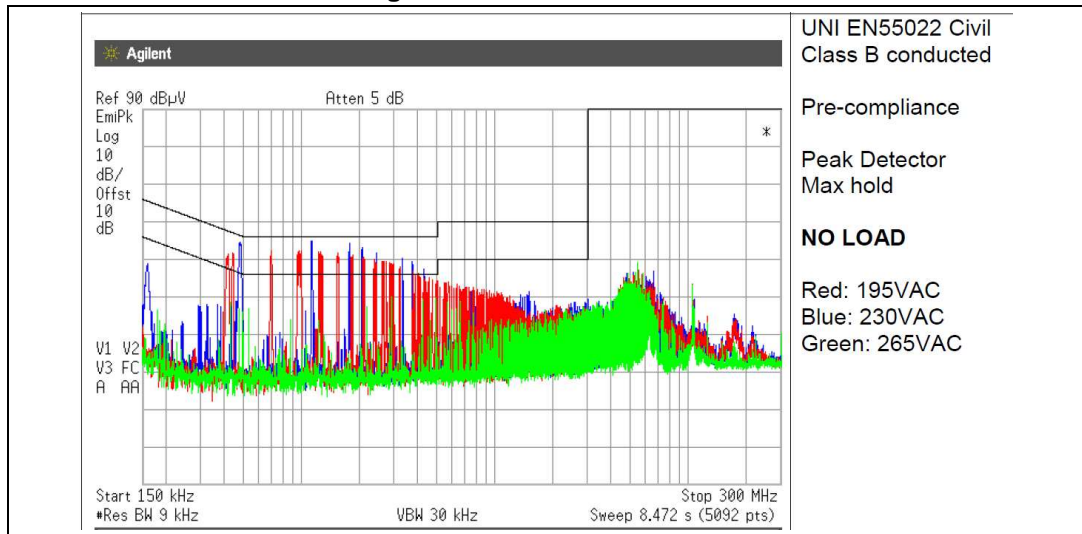

Figure 16. EMC Test No Load



## 11 Conclusion and remarks

This power supply is a high performance, low cost solution for any application requiring high peak power for a limited time. These are usually industrial applications and don't require PFC stage, such as vending machines, automatic gates, textile machinery etc.

Some features of this power supply can be enhanced with further circuitry. For example, low consumption with no load can be optimized by adding high voltage start up and a more complex compensation for burst mode versus voltage input variation.

It is possible to change the output voltage by changing the R25, R33 voltage divider and the transformer.

Transformer codes for different  $V_{OUT}$  are:

- 15 V - 18 V 300 W Peak Transformer MAGNETICA code 1860.0133
- 24 V 300 W Peak Transformer MAGNETICA code 1860.0044
- 28 V - 30 V 300 W Peak Transformer MAGNETICA code 1860.0102
- 36 V 300 W Peak Transformer MAGNETICA code 1860.0134

For voltage output greater than 35 V, limit the voltage at the TSM103W supply  $V_{CC}$  sec.



## 12 Revision history

Table 5. Document revision history

Date	Revision	Changes
03-Feb-2015	1	Initial release.

**IMPORTANT NOTICE – PLEASE READ CAREFULLY**

STMicroelectronics NV and its subsidiaries ("ST") reserve the right to make changes, corrections, enhancements, modifications, and improvements to ST products and/or to this document at any time without notice. Purchasers should obtain the latest relevant information on ST products before placing orders. ST products are sold pursuant to ST's terms and conditions of sale in place at the time of order acknowledgement.

Purchasers are solely responsible for the choice, selection, and use of ST products and ST assumes no liability for application assistance or the design of Purchasers' products.

No license, express or implied, to any intellectual property right is granted by ST herein.

Resale of ST products with provisions different from the information set forth herein shall void any warranty granted by ST for such product.

ST and the ST logo are trademarks of ST. All other product or service names are the property of their respective owners.

Information in this document supersedes and replaces information previously supplied in any prior versions of this document.

© 2015 STMicroelectronics – All rights reserved